

Wet Pilot Line Single Interlock Preaction System

4" (100mm), 6" (150mm) & 165mm Sizes

Instructions for Installation, Operation, Care and Maintenance

- 2 psi (0,14 bar) Pneumatic Supervising Pressure
- Externally Resettable Clapper
- One Main Drain

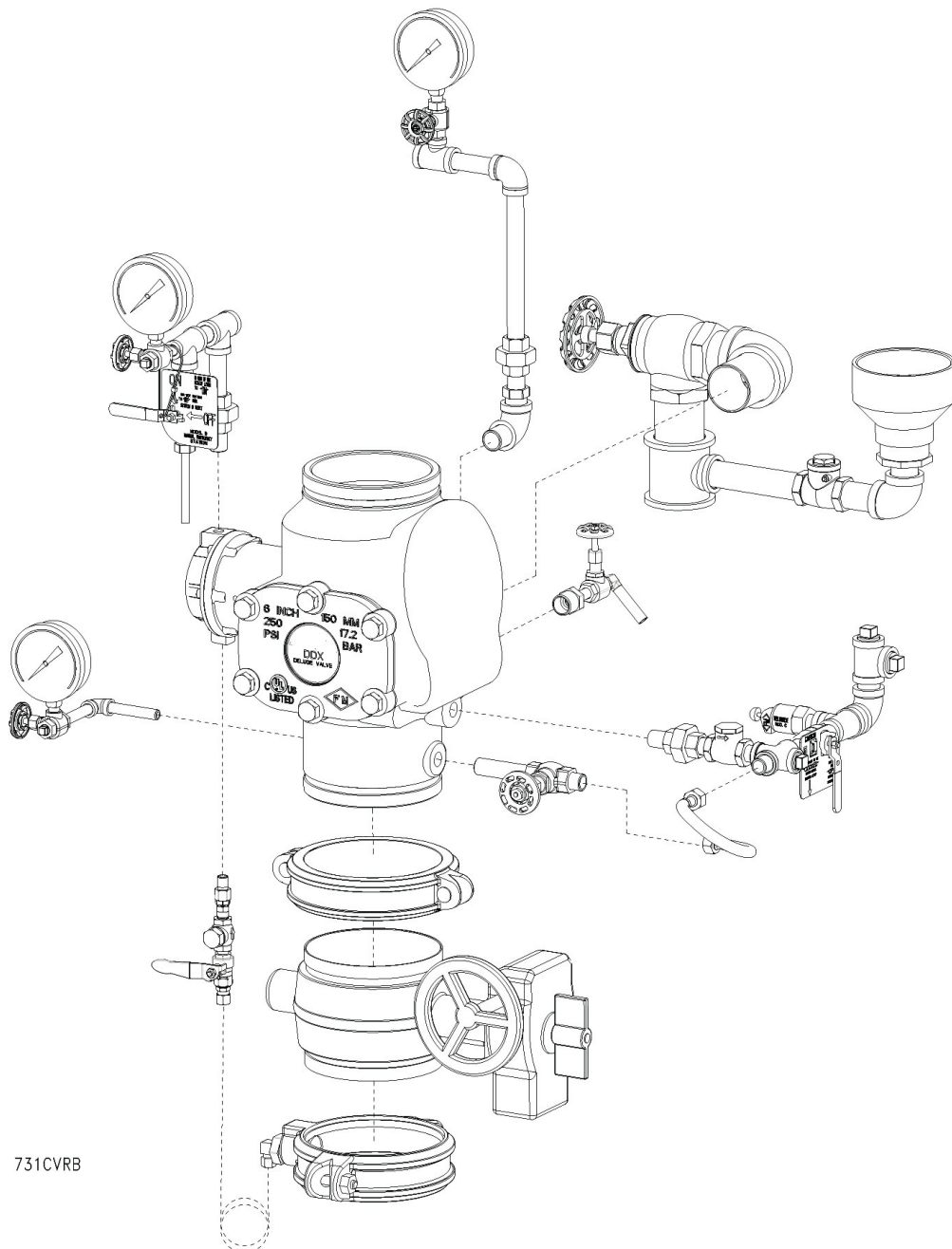



Wet Pilot Line Single Interlock Preaction System

4" (100mm), 6" (150mm) & 165mm Sizes

General Description

Single Interlock Wet Pilot Line Preaction Systems are designed for water-sensitive areas that require protection from inadvertent water flow into the sprinkler system piping. A wet pilot line consists of a line of closed sprinklers or pilot line detectors (Rapidrop's Model F1-FTR), which are located in the area to be protected. These sprinklers/detectors are more heat sensitive (lower activation temperature) than the sprinkler heads installed in the fire sprinkler system. The wet pilot line is directly installed to the Model DDX Deluge Valve's pushrod chamber. Wet pilot line sprinklers are detection devices and do not provide any water to aid in the firefighting capability of the fire sprinkler system.

To fully operate a Single Interlock Wet Pilot Line Preaction System, the heat from a fire must fuse a wet pilot line sprinkler/detector thereby releasing the water pressure from the deluge valve's pushrod chamber. As this water pressure is lost in this chamber, the main water supply will open the deluge valve's clapper, thereby flowing water into the fire sprinkler system piping. Water flowing into the system will flow through the intermediate chamber of the deluge valve to a mechanical sprinkler alarm (optional) and/or will simultaneously produce water pressure that causes the transfer of contacts in the (optional) alarm pressure switch mounted in the trim. If provided, the alarm pressure switch can electrically initiate the shutdown or start up of equipment, such as computer, HVAC, or other secondary alarm devices

(Note: the wiring contacts for the alarm pressure switch are the "Common" and "A" contacts). The flow of water into the sprinkler system piping converts the dry system into a wet system. In the event that the fire subsequently produces enough heat to operate a fire sprinkler head, water will flow from that sprinkler, controlling or suppressing the fire.

The fire sprinkler system piping may be required to be supervised (see NFPA 13) with air pressure. Loss of this supervisory air due to a damaged sprinkler or the sprinkler piping will not cause the Model DDX Deluge Valve to open. The supervisory air supply for the fire sprinkler piping may effectively be supervised by Rapidrop's Model B Air Compressor Panel or Rapidrop's Model C Pressure Maintenance Device installed in unison with a clean, dependable and continuous air or nitrogen supply (see Reliable Bulletin 252). Another option for supervisory air may be a Rapidrop Model A Air Compressor and Model B-1 Pressure Maintenance Device (see Rapidrop Bulletins 250, 251 & 275).

At the heart of Rapidrop's Wet Pilot Line Single Interlock Preaction System is the Model DDX Deluge Valve. This deluge valve is a hydraulically operated, straight-through design, differential-type (see Fig. 1). System maintenance is simplified since the deluge valve can be reset externally without removing its cover plate. This feature provides a significant system-restoration time advantage. The Model DDX Deluge Valve has an intermediate chamber and thereby does not require an in-line air check valve. Also, for ease of installation, the deluge valve only requires a single drain connection.

The trim set for the system (see Fig. 2) provides all of the necessary equipment for connections to the Model DDX Deluge Valve's push rod chamber inlet and outlet ports, the 2" (50mm) main drain, alarm devices, air supply, and required pressure gauges. This trim set is available in individual (loose) parts, in time-saving, segmentally assembled kit forms or fully assembled to the Model DDX Deluge Valve (with or without a control valve).

Listings & Approvals

Rapidrop's 4" (100mm), 6" (150mm) & 165mm Wet Pilot Line Single Interlock Preaction Systems are Underwriters Laboratories, Inc. Listed and UL certified for Canada (cULus) in the Special System Water Control Valve-Deluge Type (VLFT) category.

The NYC acceptance number for this system is MEA 258- 93-E.

Rapidrop Single Interlock Preaction Systems are UL Listed only when used with the trim components shown in Fig 2.

Wet Pilot Line Single Interlock Preaction System

4" (100mm), 6" (150mm) & 165mm Sizes

REAR VIEW OF MODEL
DDX DELUGE VALVE

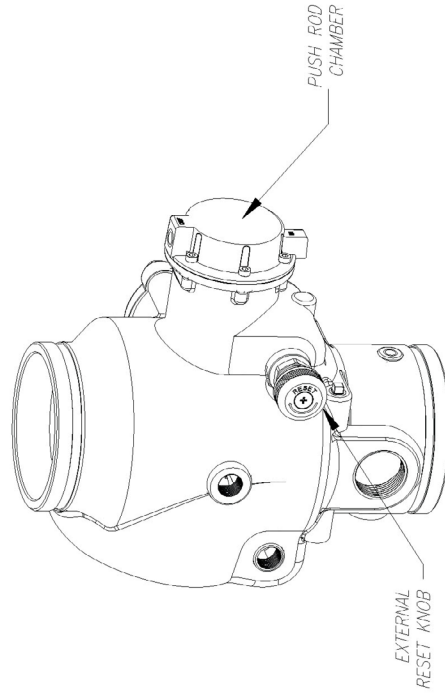

PUSH INWARD AND ROTATE KNOB CLOCKWISE TO RESET CLAPPER.
DO SO ONLY WHEN PUSH ROD CHAMBER IS UNPRESSURIZED (0 PSIG).

DDX VALVE CLAPPER IN "OPEN", "CLOSED"
AND "LATCHED" POSITIONS

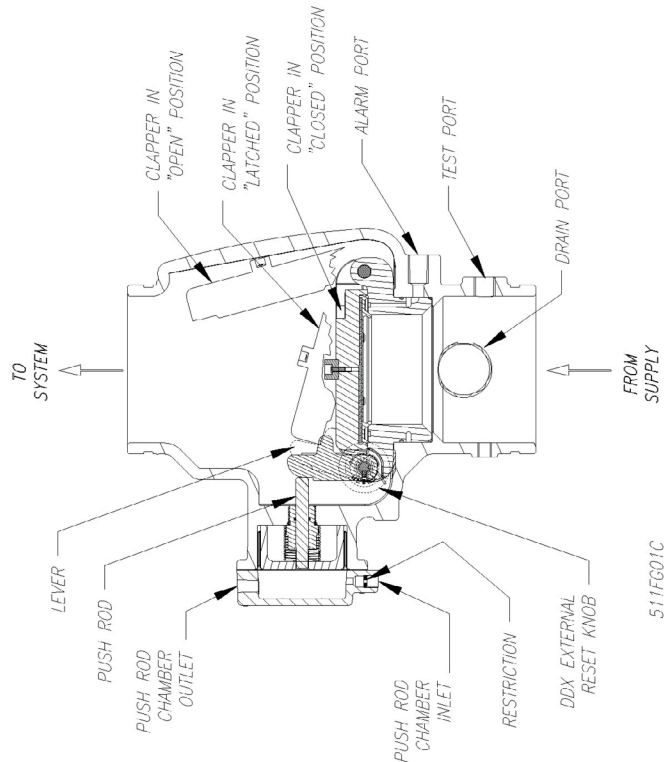
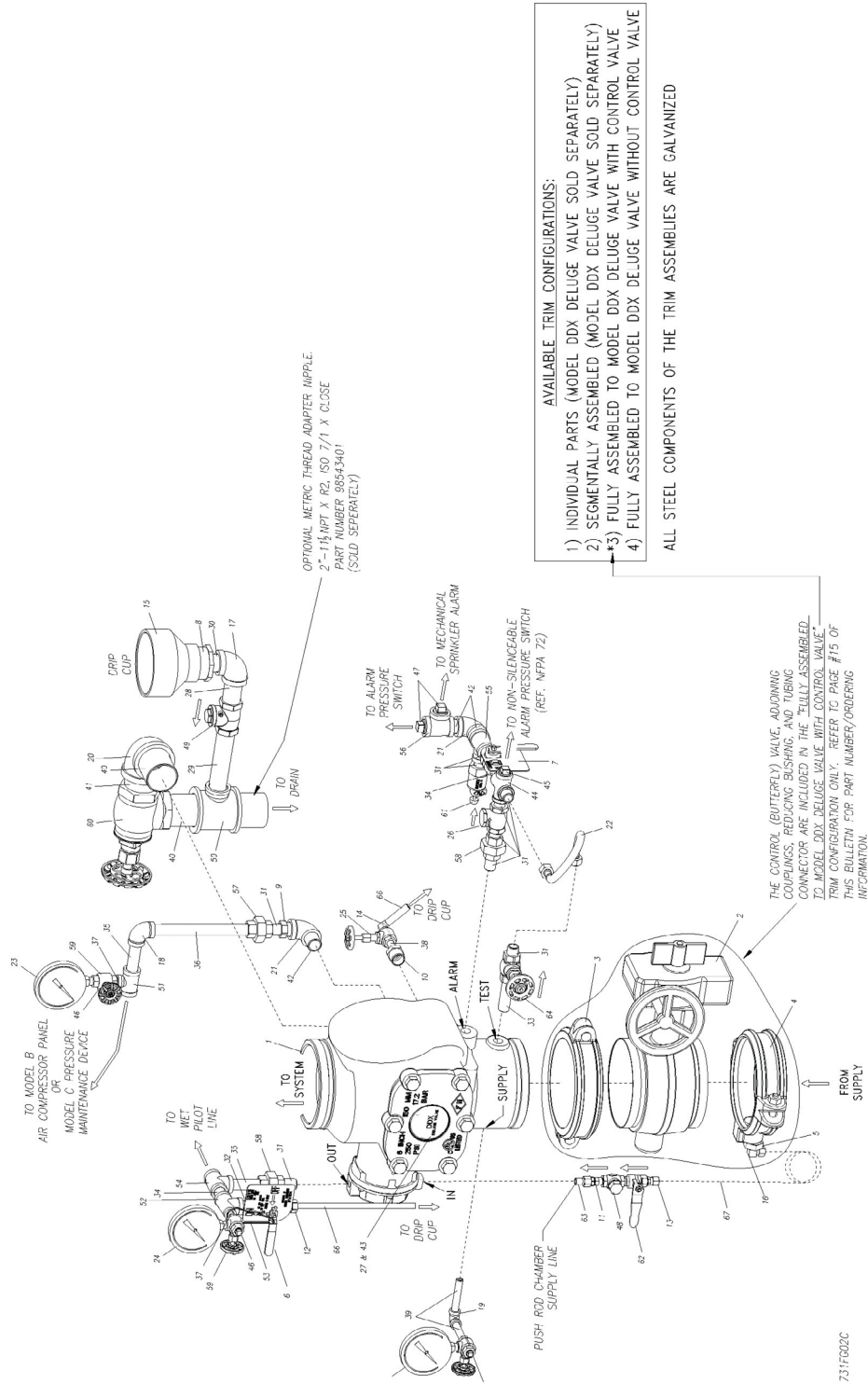

Fig.1

Wet Pilot Line Single Interlock Preaction System

4" (100mm), 6" (150mm) & 165mm Sizes

WET PILOT LINE SINGLE INTERLOCK PREACTION TRIM



- AVAILABLE TRIM CONFIGURATIONS:
- 1) INDIVIDUAL PARTS (MODEL DDX DELUGE VALVE SOLD SEPARATELY)
 - 2) SEGMENTALLY ASSEMBLED (MODEL DDX DELUGE VALVE SOLD SEPARATELY)
 - 3) FULLY ASSEMBLED TO MODEL DDX DELUGE VALVE WITH CONTROL VALVE
 - 4) FULLY ASSEMBLED TO MODEL DDX DELUGE VALVE WITHOUT CONTROL VALVE
- ALL STEEL COMPONENTS OF THE TRIM ASSEMBLIES ARE GALVANIZED

Fig.2



Wet Pilot Line Single Interlock Preaction System

4" (100mm), 6" (150mm) & 165mm Sizes

Wet Pilot Line Single Interlock Preaction Trim Parts List (Refer to Fig. 2)

Item No	Part No.	Description	Qty.
1	6103060024	Assembly, Valve, 6" For 6" Ass'y Only	1
	6103040026	Assembly, Valve, 4" For 4" Ass'y Only	
2	6215052400	Wafer-butterfly Valve, 6" For 6" Ass'y Only	1
	6215051600	Wafer-butterfly Valve, 4" For 4" Ass'y Only	
3	7g05242400	Coupling, Rigid, 6" For 6" Ass'y Only	1
	7g05161600	Coupling, Rigid, 4" For 4" Ass'y Only	
4	7d05464200	Coupling, 6" Grooved W/ 1" Npt Outlet For 6" Ass'y Only	1
	7d05444200	Coupling, 4" Grooved W/ 3/4" Npt Outlet For 4" Ass'y Only	
5	98048028	Bushing, Reducer, 1" X 1/4", Galv. For 6" Ass'y Only	1
	98048025	Bushing, Reducer, 3/4" X 1/4", Galv. For 4" Ass'y Only	
6	78653000	Assembly, Manual Emergency Station	1
7	78653004	Assembly, Valve Caution Station, 1/2"	1
8	98048015	Bushing, Reducer, 2" Spigot X 1" Nptf, Pvc	1
9	98048022	Bushing, Reducer, 3/4" X 1/2", Galv.	1
10	98048025	Bushing, Reducer, 3/4" X 1/4", Galv.	1
11	98840147	Check Valve, 1/4" Npt, Poppet Type Inline	1
12	92056810	Connector, 3/8" ID Tube X 1/2" Npt	1
13	92056702	Connector, 3/8" Tubing X 1/4" Npt	1
14	92056705	Connector, Elbow, 3/8" ID Tube X 1/4" Npt	1
15	98050004	Drain Cup, Pvc	1
16	92056703	Elbow, Male, 3/8" Tube X 1/4 Npt	1
17	98174403	Ell, 1", Mall Iron, Galv.	1
18	98174401	Ell, 1/2", Mall Iron, Galv.	1
19	98174404	Ell, 1/4", Mall Iron, Galv.	1
20	98174405	Ell, 2", Mall Iron, Galv.	1
21	98174402	Ell, 3/4", Mall Iron, Galv.	2
22	96920912	Flex Line, 12"	1
23	98248000	Gauge, Air Pressure (0-80 Psi)	1
24	98248001	Gauge, Water Pressure (0-300 Psi)	2
25	98840172	Globe Valve, 1/4"	1
26	98840181	Horiz. Swing Check Valve, 1/2" Npt	1
27	94616915	Nameplate, Deluge Valve	1
28	98543222	Nipple, Steel, Galv., 1" X 3-1/2"	1
29	98543266	Nipple, Steel, Galv., 1" X 6"	1
30	98543213	Nipple, Steel, Galv., 1" X Close	1
31	98543223	Nipple, Steel, Galv., 1/2" X 1-1/2"	9
32	98543210	Nipple, Steel, Galv., 1/2" X 2-1/2"	1
33	98543228	Nipple, Steel, Galv., 1/2" X 4-1/2"	1
34	98543209	Nipple, Steel, Galv., 1/2" X 2"	2
35	98543230	Nipple, Steel, Galv., 1/2" X 3"	2
36	98543237	Nipple, Steel, Galv., 1/2" X 8"	1
37	98543226	Nipple, Steel, Galv., 1/4" X 1-1/2"	2
38	98543244	Nipple, Steel, Galv., 1/4" X 2"	1

Item No	Part No.	Description	Qty.
39	98543220	Nipple, Steel, Galv., 1/4" X 3"	2
40	98543208	Nipple, Steel, Galv., 2" X 3"	2
41	98543238	Nipple, Steel, Galv., 2" X Close	1
42	98543279	Nipple, Steel, Galv., 3/4" X Close	3
43	99080002	Pad-adhesive	1
44	98750003	Pipe Cross, 1/2", Galv.	1
45	98604406	Plug, Iron, Sq. Hd., 1/2"	1
46	98614403	Plug, Iron, Sq. Hd., 1/4"	3
47	98614401	Plug, Iron, Sq. Hd., 3/4"	2
48	98727607	Strainer, 1/4"	1
49	98840145	Swing Check Valve, 1" Npt	1
50	96606627	Tee, Glvn, 2" X 2" X 1"	1
51	96606607	Tee, Glvn., 1/2" X 1/2" X 1/4"	1
52	98761649	Tee, Glvn., 1/2" X 1/4" X 1/2"	1
53	89141112	Tie, Retaining	9
54	98761651	Tee, Glvn., 1/2"	1
55	96606612	Tee, Glvn., 3/4" X 1/2" X 1/2"	1
56	96606601	Tee, Glvn., 3/4"	1
57	98815204	Union, "O" Ring Seal, Galv., 1/2"	1
58	98815200	Union, 1/2", Iron, Galv.	2
59	98840160	Valve, 3-way, 1/4"	3
60	98840100	Valve, Angle, 2"	1
61	78653100	Valve, Ball Drip, 1/2"	1
62	98840117	Valve, Ball, 1/4" Nptf X 1/4" Nptm	1
63	98840187	Valve, Check, 1/4" Nptf X 1/4" Nptm	1
64	98840171	Valve, Globe, 1/2"	1
65	----	----	--
66	96686754	Tubing, Pvc, 3/8" ID X 4 Ft.	1
67	98768008	Copper Tubing, 3/8"	30"

System Operation

To fully operate (deliver water) a Wet Pilot Line Single Interlock Preaction System, two independent events must take place before water flow will occur. A wet pilot line sprinkler/detector must fuse along with a fire sprinkler head. Operation of either one of these heads will cause an alarm to annunciate, but will not cause water discharge from the fire sprinkler system piping.

When set correctly for service, the Model DDX Deluge Valve is hydraulically established to withhold the supply water from the sprinkler system piping. The Rapidrop Model DDX Deluge Valve is shown in both closed and open positions in Fig. 1. In the closed position, the supply pressure acts on the underside of the clapper and also on the push rod through the push rod chamber's inlet restriction. The resultant force due to the supply pressure acting on the push rod is multiplied by the mechanical advantage of the lever and is more than sufficient to hold the clapper closed against normal supply pressure surges.

Wet Pilot Line Single Interlock Preaction System

4" (100mm), 6" (150mm) & 165mm Sizes

When a fire is detected, the opened wet pilot line sprinkler/detector vents the push rod chamber to atmosphere through the chamber's outlet. Since the pressure cannot be replenished through the inlet restriction as rapidly as it is vented, the push rod chamber pressure falls instantaneously. When the push rod chamber pressure approaches approximately one-third of the supply pressure, the upward force of the supply pressure acting beneath the clapper overcomes the lever-applied force thereby opening the clapper.

Once the clapper has opened, the lever acts as a latch, preventing the clapper from returning to the closed position. Water from the supply flows through the Deluge Valve into the system piping. Water also flows through the Deluge Valve alarm outlet to the alarm devices.

After system shutdown, resetting the Model DDX Deluge Valve is quite simple. Doing so only requires pushing in and turning the reset knob at the rear of the valve (see Fig 1). The external reset feature of the Model DDX Deluge Valve provides a means for simple, economical system testing, which is one essential facet of a good maintenance program. The external reset feature does not, however, eliminate another important facet of good maintenance, namely, periodic cleaning and inspection of the internal valve parts. In the event that water builds up inside the valve due to condensate from the air supply system or water left inside from valve system testing, a drain is available for venting. After closing the main supply valve, a small

valve over the drain cup can be opened slightly until the water inside the valve body and the main pipe column has drained. See the section titled "Draining Excess/Condensate Water From System" in this bulletin for the detailed procedure.

The Model B Manual Emergency Station (see Fig. 4) is also included in the Reliable Single Interlock Preaction System trim set. It consists of an aluminium nameplate mechanically attached to a ball valve. The valve handle in its OFF position is guarded against accidental turning to the ON position (and system discharge) by a nylon cable tie provided with each trim kit. The cable tie is inserted, as shown in Fig. 4, after the system has been restored for operation. The nylon cable tie is designed to allow, in case of an emergency, forceful turning of the valve handle to the ON position. As an alternative to the Model B Hydraulic Manual Emergency Station, the Model A Hydraulic Manual Emergency Pull Box (see Reliable Bulletin 506) is also available and can be provided as an option.

Whenever ambient temperature conditions are high, the water temperature in the Model DDX Deluge Valve's pushrod chamber could possibly increase, thereby increasing the pressure in the chamber to values exceeding the rated pressure of the system. In an indoor installation where standard room temperatures are exceeded, a pressure relief kit may be needed. Pressure relief kit, PIN 6503050001, can be installed into the pushrod chamber's releasing line to limit the pressure to 175 psi (12,1 bar).

WET PILOT LINE HEIGHT vs LENGTH

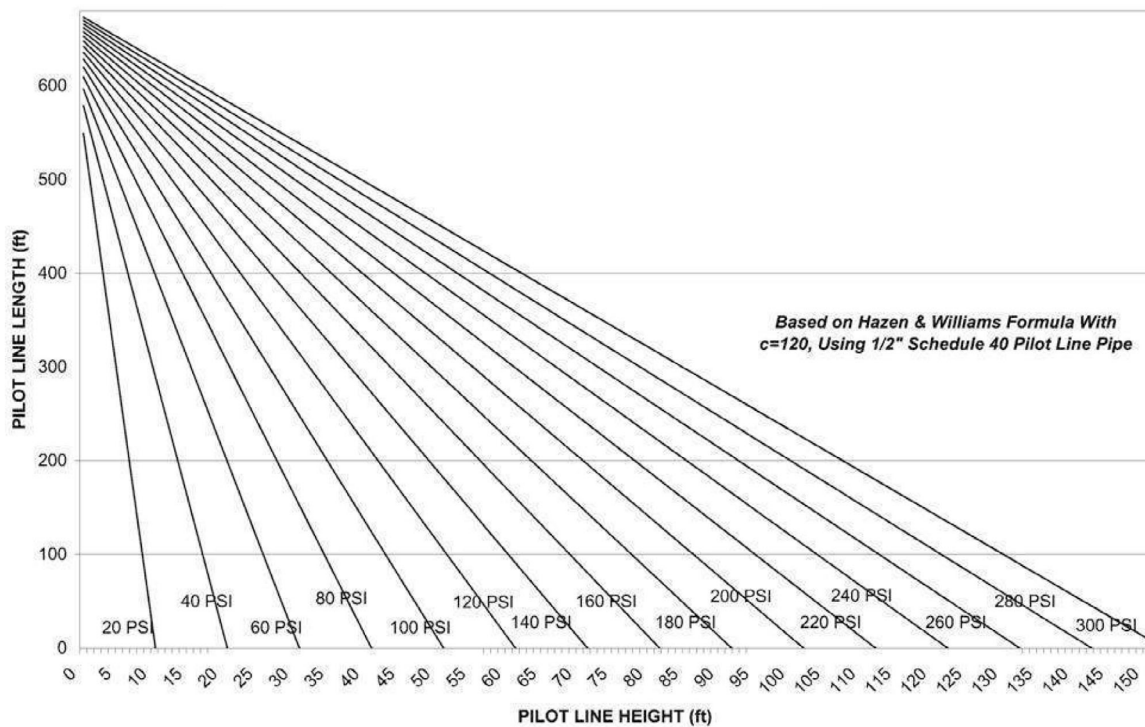

Fig.3



Wet Pilot Line Single Interlock Preaction System

4" (100mm), 6" (150mm) & 165mm Sizes

Pressurizing Line Connection

The water supply for the push-rod chamber must be provided by connection of its inlet pressurizing line to the water supply piping. Pressurizing lines for multiple Model DDX Deluge Valve push-rod chambers must never be manifolded together, having only a single tap on the water supply piping. Each Model DDX Deluge Valve must have its own push-rod chamber pressurizing line connection. This connection must be made on the supply side of the main water supply control valve. This can be accomplished by:

a. Using a tapped connection directly below or next to the main water supply control valve using a welded outlet or the appropriate mechanical fittings. A grooved-end outlet coupling is one way to achieve this (see Fig. 2); or b. Using a water supply control valve that has an available threaded (NPT) supply-side tap design to allow for a direct water supply connection to the Model DDX Deluge Valve's push-rod chamber.

Caution: Rapidrop's DDX valve is designed with an inlet restriction built into the pushrod chamber. It is important not to introduce additional restrictions into the direct water supply connection or the discharge from the pushrod chamber by installing additional valves or improperly installing the copper lines used in the trim of the valve.

Hydrostatic Testing of DDX Valves and DDX Systems

As required by NFPA 13, fire sprinkler systems with working pressures up to and including 150 psi are to be hydrostatically tested at a water pressure of 200 psi and maintain that pressure without loss for two hours. Fire sprinkler systems with working pressures above 150 psi are required to be hydrostatically tested at 50 psi above the system working pressure and maintain that pressure without loss for two hours. In addition to the hydrostatic tests described above, dry pipe and double interlock preaction systems require an additional low pressure air test.

In some cases, hydrostatic testing (in accordance with the NFPA 13 requirements noted above) will result in pressures that exceed the working pressure of the valve and trim kit for the two-hour test period. The valve and applicable trim kit have been tested, approved and listed under these conditions and as such, hydrostatic testing in accordance with NFPA 13 is acceptable. In addition, the clapper can remain in the closed position and the trim kit need not be isolated, as each has been designed to withstand hydrostatic testing as required by NFPA 13.

Hydrostatically testing the valve and trim to pressures higher than their rating is limited to the hydrostatic test as referenced by NFPA 13. It does not address the occurrence(s) of a "water hammer" effect, which can indeed damage the valve. A "water hammer" in the water supply piping of the valve can create pressures in excess of the rated pressure and should be avoided by all necessary means. This condition may be created from improper fire pump settings, underground construction work or an improper venting of trapped air in the water supply piping.

System Design Considerations

The automatic sprinklers, wet pilot line sprinklers/detectors, and signaling devices which are utilized with the Wet Pilot Line Single Interlock Preaction System must be UL or ULC Listed, as applicable.

The Deluge Valve, and all interconnecting piping must be located in a readily visible and accessible location and in an area that can be maintained at a minimum temperature of 40°F (4°C). Note: Heat tracing is not permitted. Pendent sprinklers, other than dry pendants, used on preaction systems shall be installed on return bends per NFPA 13.

The wet pilot line is only a detection system and does not contribute to controlling the fire. Its installation is subject to the following restrictions:

- It is not to be installed in an area subject to freezing.
- It is not to be installed in an area where temperatures in excess of 150°F (65°C) are anticipated.
- NFPA 72 or the authority having jurisdiction should be consulted for spacing and elevation requirements.
- Maximum wet pilot line length and height must comply with data provided in Fig. 3.

System Air Pressure Requirements

A Rapidrop Model B Air Compressor Panel or Model C Pressure Maintenance Device is used to maintain the system pneumatic pressure at approximately 35 oz/in² (2.2 psi or 0,2 bar). The air compressor panel contains an integral low air pressure warning light, while the pressure maintenance device requires a separate annunciating device to be connected to the low pressure switch. The switch is factory set to transfer contacts when the supervisory pressure falls below approximately 11 oz/in² (0.7 psi or 0,05 bar). The pressure maintenance device is a supervisory pneumatic supply for use where a clean, dependable and continuous compressed air or dry nitrogen gas source is available in the 40 to 100 psi (2,8 to 6,9 bar) pressure range.

In some circumstances, such as when dry sprinklers are being used in a preaction system, it may be desirable to supervise the preaction system at air pressures higher than 2 psi. For such cases, Rapidrop recommends the use of an A-2 air maintenance device with either a System Sensor EPS-10 or EPS-40 low air pressure switch. Supervising air pressure may be between 7psi and 20 psi, depending on which low air pressure switch is being utilized.

Wet Pilot Line Single Interlock Preaction System

4" (100mm), 6" (150mm) & 165mm Sizes

MODEL B HYDRAULIC MANUAL EMERGENCY STATION

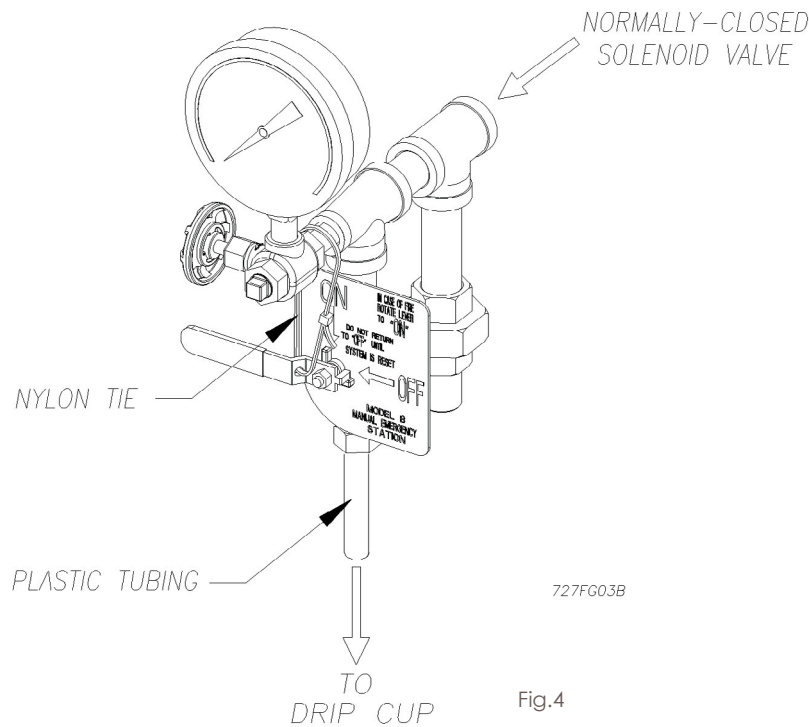

Fig.4

Wet Pilot Line Single Interlock Preaction System- Trim Engineering Specifications

General Description

Preaction system shall be a single interlock preaction system utilizing a [4" (100 mm)] [6" (150 mm)] [165mm] [cULus Listed] hydraulically operated, differential latching clapper type valve with wet pilot line release preaction trim. Deluge valve shall be of lightweight, ductile-iron construction with "drop in" bronze seat and clapper assembly. Bronze seat shall have O-ring seals to resist corrosion and leakage. Clapper facing shall be pressure actuated, providing a limited compression seat for the sealing force between the clapper rubber facing and the valve seat. Push-rod chamber shall be of a piston/push-rod design with diaphragm seal and have a 1/8" vent hole for air/water leakage indication. Trip ratio shall be a 3: 1 force differential. Deluge valve shall be of the straight-through design to minimize friction loss, and be capable of being reset without having to remove the valve cover plate through the use of an external reset knob. Inlet restriction orifice shall be factory installed into inlet port of deluge valve push-rod cover plate and not be a separate part of the deluge valve trim. Valve end connections shall be grooved outlets per ANSI/AWWA C606. Deluge valve shall have a rated working pressure of 250 psi (17,2 bar). Deluge valve to be [4" (100 mm)] [6" (150 mm)] [165mm] Reliable Model DDX Deluge Valve (Bulletin 511).

Supervisory Air Supply Options Owner's Air supply

Single interlock preaction system air pressure shall utilize low supervisory air pressure. Air supply shall be provided by an owner supplied air system in conjunction with a [cULus Listed] automatic low air pressure maintenance device. The pressure maintenance device trim assembly shall consist of a field adjustable, low pressure line regulator, air filter assembly, low air pressure switch, pressure gauge and check valve. Regulator shall be capable of receiving 40 to 100 psi (2,8 to 6,9 bar) inlet pressure and provide approximately 2 psi (0,14 bar) outlet supervisory pressure. The pressure switch shall have a SPDT contact rated at 15 amp @ 125/250 VAC, and 10 amp @ 12 VDC. Pressure switch shall transfer contacts when the supervisory pressure falls below approximately 0.5 psi (0.03 bar).



Wet Pilot Line Single Interlock Preaction System

4" (100mm), 6" (150mm) & 165mm Sizes

Low Pressure Air Compressor Panel

Preaction system supervisory air supply shall be a [cULus Listed] self-contained, low pressure air compressor panel containing a 1/16 hp air compressor, DPDT relay for remote supervisory annunciation, horn for local audible alarm, pressure gauge, and low pressure alarm switch. Pressure switch shall control the compressor, providing a maximum operating supervisory pressure of 2 psi (0,14 bar), and a lowpressure supervisory alarm at approximately 0.5 psi (0,03 bar). Power requirements shall be 120 VAC/60 Hz.

Optional System Accessories System Control Valve

Preaction system control valve shall be a slow close, [cULus Listed] indicating butterfly type valve with a pre-wired supervisory tamper switch assembly. The valve shall be rated for a working pressure of [175 psi (12,1 bar)] [250 psi (17,2 bar)]. System control valve shall be a [4" (100 mm)] [6" (150 mm)] [165mm] Rapidrop Butterfly Valve.

Waterflow Alarm Pressure Switch

Alarm pressure switch shall be provided to indicate water flow and provide a water flow alarm. Pressure switch shall be [cULus Listed] and of the bellows activated type enclosed in a weatherproof, 4x, NEMA 4-rated enclosure incorporating tamper-resistant screws. There shall be two sets of SPDT (Form C) contacts rated at 10.0 A @ 125/250 VAC and 2.5 A @ 6/12/24 VDG. The pressure switch shall have a maximum service pressure rating of 250 psi (17,2 bar) and shall be factory adjusted to operate at a pressure of 4 to 8 psi (0,27 to 0,55 bar) with adjustment up to 20 psi (1,3 bar). Switch shall be provided with a 1/2" NPT male pressure connection. Waterflow alarm pressure switch shall be System Sensor EPS1 0-2.

Technical Data

Rapidrop Wet Pilot Line Single Interlock Preaction Systems, with associated trim, sizes 4" (100mm), 6" (150mm) and 165mm are rated for use at minimum water supply pressure of 20 psi (1,4 bar) and maximum supply pressure of 250 psi (17,2 bar). Water supplied to the inlet of the valve and to the pushrod chamber must be maintained between 40°F (4°C) and 140°F (60°C).

The following list of technical bulletins pertains to valves and devices that may be used in this preaction system:

Deluge Valve	510/511
Hydraulic Emergency Station (Model A)	506
Mechanical Sprinkler Alarm	612/613
Pressure Maintenance Device	252
Air Compressor Panel (Models B & C)	252
Electric Emergency Station	700
Fire Alarm Devices	700
Waterflow/Low Air Pressure Alarm Switch	System Sensor A05-0176
Pilot Line Detector	180

Valve Description

1. Rated working pressure: Valve & System - 250 psi (17,2 bar)
2. Factory tested to a hydrostatic pressure of 500 psi (34,5 bar). (Valve only)
3. End and trim connections:
 - ANSI/AWWA C606 grooved inlet and outlet

Groove Dimensions

Valve Size	Outlet Diameter	Groove Diameter	Groove Width	Outlet Face to Groove
4" (100 mm)	4.500" (114 mm)	4.334" (110 mm)	3/8" (10 mm)	5/8" (16 mm)
6" (150 mm)	6.625" (168 mm)	6.455" (164 mm)		
165 mm	6.500" (165 mm)	6.330" (161 mm)		

- Threaded openings Per ANSI B 2.1

Valve Size	Color
4" (100 mm)	Black
6" (150 mm)	
165mm	Red

4. Face to face dimensions:
 - 4" (100 mm) - 14" (355 mm)
 - 6" (150 mm) & 165 mm - 16" (406 mm)
5. Shipping weight:

Valve Size	Weight
4" (100 mm)	64 lb. (29 kg)
6" (150mm) & 165mm	95 lb. (43 kg)

6. Friction loss (Expressed in equivalent length of Schedule 40 pipe, based on Hazen & Williams formula with C= 120 and a flow velocity of 15ft/sec (4.6 m/sec)):

Valve Size	Equivalent Length
4" (100 mm)	14' (4,27 m)
6" (150 mm) & 165 mm	29.4' (9 m)

7. Installation position: Vertical

Maintenance

Rapidrop Wet Pilot Line Single Interlock Preaction Systems and associated equipment shall periodically be given a thorough inspection and test. NFPA 25, Inspection, Testing and Maintenance of Water Based Fire Protection Systems, provides minimum maintenance requirements. System components shall be tested, operated, cleaned, and inspected at least annually, and parts replaced as required.



Wet Pilot Line Single Interlock Praction System

4" (100mm), 6" (150mm) & 165mm Sizes

Resetting the Single Interlock Praction System

Refer to Figs. 2, 5, and 6.

1. Close the main valve controlling water supply (Fig. 6) to the Deluge Valve and close off the air supply to the sprinkler system.
2. Close the pushrod chamber supply valve, valve A (Fig. 6).
3. Open the main drain valve, valve B (Fig. 6), and drain system.
4. Open all drain valves and vents at low points throughout the system, closing them when flow of water has stopped. Open valve D (Fig. 6).

Note: The above steps accomplish the relieving of pressure in the push rod chamber of the Deluge Valve.

5. With valve G (Fig. 6) open, push in the plunger of ball drip valve, valve E (Fig. 6), to force the ball from its seat, and drain any water in the alarm line.
6. With the Model B Manual Emergency Station, valve D (Fig. 6), open, push in and rotate the Deluge Valve's external reset knob (#38, Fig. 5) clockwise until you hear a distinct clicking noise, indicating that the clapper has closed. Note: The reset knob can be rotated only after pressure in the pushrod chamber is reduced to atmospheric conditions (0 psig).
7. Inspect and replace any portion of the sprinkler system subjected to fire conditions.
8. Open valve A (Fig. 6) and allow water to fill the Deluge Valve's pushrod chamber. Close valve D (Fig. 6).
9. Bleed the entire wet pilot line until all air is removed at the most remote sprinkler.

Note: All detection devices must be reset before the releasing/control panel can be reset.

10. Close valve G (Fig. 6). Open the valve to restore air pressure in the sprinkler system.
11. Open valve G (Fig. 6). Open slightly the main valve controlling water supply (Fig. 6) to the Model DDX Deluge Valve, closing drain valve B (Fig. 6) when water flows. Observe if water leaks through the ball drip valve, valve E (Fig. 6), into the drip cup, J (Fig. 6). If no leak occurs, the Deluge Valve's clapper is sealed. Open slowly, and verify that the main valve controlling water supply is fully opened and properly monitored.
12. Verify that valve A (Fig. 6) and valve G (Fig. 6) are open.
13. Secure the handle of the Model B Manual Emergency Station, valve D (Fig. 6), in the OFF position with a nylon tie (#53, Fig. 2).

Inspection and Testing

Refer to Figs. 2, 5, and 6.

1. Water supply - be sure the valve(s) controlling water supply to the Deluge Valve are opened fully and properly monitored.
2. Alarm line - be sure that valve G (Fig. 6) is opened and remains in this position.
3. Other trimming valves - check that valve A (Fig. 6) is open as well as all of the pressure gauge's 3-way valves. Valves D, F, and H (Fig. 6) should be closed.

4. Ball drip valve E (Fig. 6) - make sure that valve G (Fig. 6) is open. Push in on the plunger to be sure the ball check is off its seat. If no water appears, the Deluge Valve's water seat is tight. Inspect the bleed hole (see Fig. 5) on the underside of the push rod chamber for leakage.
5. System pneumatic pressure - check that system air pressure is approximately 35 oz/in² (2.2 psi or 0,2 bar). Check the pressure maintenance device for leakage and proper pressure.
6. Releasing device - check the wet pilot line and the Model B Manual Emergency Station, valve D (Fig. 6) for leakage. Also verify that the tubing drain line from the Model B Manual Emergency Station is not pinched or crushed which could prevent proper releasing of the Deluge Valve.
7. Testing alarms - make sure that valve G (Fig. 6) is open. Open valve F (Fig. 6) permitting water from the supply to flow to the electric sprinkler alarm switch and to the mechanical sprinkler alarm (water motor). After testing, close this valve securely. Push in on the plunger of ball drip valve E (Fig. 6) until all of the water has drained from the alarm line.
8. Operational test - Open the Model B Manual Emergency Station, valve D (Fig. 6). Note: An operational test will cause the Deluge Valve to open and flow water into the sprinkler system.
9. Secure Model B Manual Emergency Station, valve D (Fig. 6), in the OFF position with a nylon tie (#53, Fig. 2) after the Deluge Valve is reset.

Testing the Model DDX Deluge Valve With-out Flowing Water

Refer to Fig. 6

1. Close the valve controlling water supply to Deluge Valve and open the main drain valve B.
2. Verify that valve A is open, allowing water to enter the push rod chamber.
3. Operate detection system - open the Model B Manual Emergency Station Valve D.
4. Operation of the detection system will result in a sudden drop of water pressure in the push rod chamber.
5. Reset detection system - reverse operations performed in step three above and then proceed according to the directions listed in the "Resetting the Single Interlock Praction System" section of this bulletin for resetting the Deluge Valve.



Wet Pilot Line Single Interlock Preaction System

4" (100mm), 6" (150mm) & 165mm Sizes

Draining Excess/Condensate Water From System

Refer to Fig. 6

1. Close the main valve controlling water supply to Deluge Valve. Also close valve A and open main drain valve B.
2. Open condensate drain valve H until all water has drained. Close valve H. Note: Be sure not to keep valve H open for an extended period of time because that will cause enough system air to bleed off thereby causing an undesirable activation of a trouble-annunciating device.
3. Close main drain valve B. If system contains pressurized air, allow air pressure to come back up to specification. Open valve A first, and then open the main valve controlling the water supply to the Deluge Valve.

Maintenance Procedures - Model DDX Deluge Valve

Refer to Figs. 2, 5, & 6.

1. Mechanical sprinkler alarm (water motor-not shown) not operating: This is most likely caused by a clogged screen in the strainer of the water motor. Proceed as follows: Remove plug from the strainer. Remove and clean the screen. Replace the screen and the plug, and then tighten securely (Ref. Bulletin 613).
2. Leakage out of the ball drip valve E (Fig. 6).
 - a. Water leakage due to a water column above the Deluge Valve's clapper:

This condition can be caused by leakage past the system side of the Model DDX Deluge Valve's seal faceplate subassembly (#5, Fig. 5). Be sure that this surface is free of any type of debris. To eliminate leakage due to a water column, refer to the section in this bulletin marked "Draining Excess/Condensate Water From System". If the problem continues proceed to the following section.
 - b. Leakage, air or water from the ball drip valve, E (Fig. 6): If system air is leaking out the ball drip valve, the problem is either damage to the airside of the Model DDX Deluge Valve's seal faceplate subassembly (#5, Fig. 5), seat (#2, Fig. 5), or the upper seat O-ring (#11, Fig. 5).

If supply water is leaking out the ball drip valve the problem could be caused by damage to the Model DDX Deluge Valve's seal faceplate subassembly (#5, Fig. 5), seat (#2, Fig. 5), or lower seat O-ring (#11, Fig. 5). The following section provides instructions to correct both conditions:

- A. Shut down the valve controlling the water supply to the Deluge Valve and open the main drain valve B (Fig. 6). Open the water column drain valve H (Fig. 6). Close the push rod chamber supply valve A (Fig. 6) and open the Model B Manual Emergency Station D (Fig. 6).

- B. Remove the Deluge Valve's front (handhold) cover (#4, Fig. 5) and inspect the seat (#2, Fig. 5), clapper (#3, Fig. 5), and seal faceplate subassembly (#5, Fig. 5) for damage.

If inspection indicates damage to the clapper (#3, Fig. 5) or seal faceplate subassembly (#5, Fig. 5) only, then the clapper subassembly can be removed as follows:

At the rear of the valve, disconnect the water column drain trim starting with the elbow connector (#14, Fig. 2). Then remove the 1/4" globe valve (#25, Fig. 2), followed by the 3/4" x 1/4" reducing bushing (#10, Fig. 2). Remove the retaining ring (handhold cover side) from the clapper hinge pin (#14, Fig. 5) and push this pin through the water column drain line and remove the clapper subassembly. Remove the four retaining screws (#24, Fig. 5) holding the seal faceplate subassembly (#5, Fig. 5). Inspect the clapper (#3, Fig. 5) visually before re-installing. Apply a small amount of siliconebased lubricant to the four retaining screws. Install a new seal faceplate subassembly. Torque the retaining screws to approximately 40 inch-pounds and reassemble. If the seat (#2, Fig. 5) is damaged or it is suspected that the leakage is through the lower O-ring (#11, Fig. 5), the seat-clapper subassembly is easily removed as a unit as follows: Using a 5/16" Allen wrench, remove the two 3/8" NPT pipe plugs (#19 (not shown) Fig. 5) located on the side of the Model DDX Deluge Valve. The seat-clapper subassembly is retained by two locking pins (#17 (not shown) Fig. 5). The centers of these pins have a 1/4"-20 threaded hole. Remove the two locking pins by engaging them with a 1/4"-20 screw or threaded rod and pulling them out (The two locking pins are not threaded, so turning them with the attached 1/4"-20 screw or threaded rod is not recommended. A proven method is to use 1/4"-20 threaded rod with a locknut on the unassembled end. Grab hold of the locknut with pliers or vice-grips and tap the pliers or vice-grips in the direction away from the Deluge Valve. Doing so should pull the locking pins out of the Deluge Valve.). With the clapper (#2, Fig. 5) in the closed position (not latched), dislodge the seat-clapper subassembly from the Valve's body by inserting two slotted screwdrivers under the lever and clapper mounting ears and pry up until the seat-clapper subassembly is free of its bore. Reach into the valve and grasp the seat-clapper subassembly from the sides. Lift up and rotate the seat-clapper subassembly.

Wet Pilot Line Single Interlock Preaction System

4" (100mm), 6" (150mm) & 165mm Sizes

MODEL DDX DELUGE VALVE [4" (100), 6" (150MM) & 165MM]

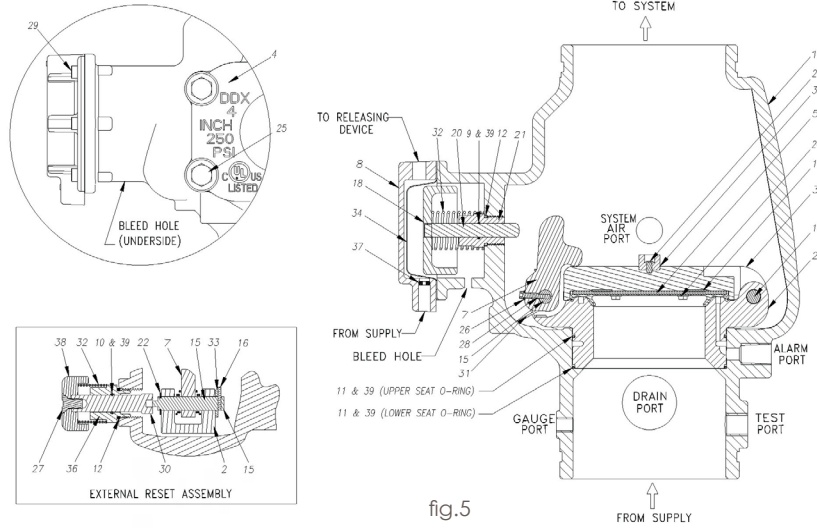

511FG08F

Models DDX 4" (100mm), 6" (150mm) & 165mm Deluge Valve Parts List

Item No	Part Number			Description	Qty.
	4" (100mm) Valve	6" (150mm) Valve	165mm Valve		
1	91006005	91006007	91006027	Valve Body	1
2	96016004	96016006	96016006	Seat	1
3	91916004	91916006	91916006	Clapper	1
4	92116064	92116066	92116065	Cover	1
5	93416004	93416006	93416006	Seal Faceplate Subassembly	1
6	93706004	93706006	93706006	Gasket, Cover (Not Shown)	1
7	94506004	94506006	94506006	Lever	1
8		92126006		Cover, Pushrod	1
9		95406407		O-ring (014)	1
10		95406007		O-ring (114)	1
11	95406006	N/A		Oring (156)	2
	N/A	95406016		Oring (151)	
12		95406024		O-ring (912)	2
13	93706001	N/A	N/A	Gasket, Clapper, 4"	1
	N/A	93706002	93706002	Gasket, Clapper, 6"	1
14		96216086		Hinge Pin, Clapper	1
15		96216046		Pin, Lever	1
16		95606131		Threaded Stud, #10-32 x 3/4"	1
17		96216066		Pin, Locking, Seat (Not Shown)	2
18		95106006		Piston	1
19		95200038		Plug, Socket, Ø 3/8" - 18 NPT (Not Shown)	2
20		95506006		Pushrod	1
21		93916006		Pushrod Guide	1

Item No	Part Number			Description	Qty.
	4" (100mm) Valve	6" (150mm) Valve	165mm Valve		
22		95306267		Ring, Retaining (2 Assembled to Item No. 14)	3
23		95606128		Screw, Button Head, #10-32 x 3/8"	1
24		95606129		Screw, Hex Washer Head, #10-32 x 3/8"	4
25	95606107	N/A	N/A	Screw, Hex Cap, Ø 1/2" - 13 x 1-1/2"	6
25	N/A	91106006	91106006	Screw, Hex Cap, Ø 5/8" - 11 x 1-3/4"	
26		96906111		Spring Lock Washer, #10	1
27		95606127		Screw, C'sunk Cap Head, Ø 3/8" - 16 x 3/4"	1
28		95606130		Screw, Socket Head, #10-32 x 1"	1
29		95606114		Screw, Socket Head, Ø 1/4" - 20 x 5/8"	6
30		93916066		Shaft, Reset	1
31		96406004		Spring, Lever	1
32		96406906		Spring	2
33		96906904		Teflon Washer, Ø 1/2" (2 Assembled to Item No.14)	3
34		95276006		Diaphragm	1
35		92306006		Disc, Bumper	1
36		94106066		Housing, Reset	1
37		94206406		Inlet, Orifice	1
38		94356006		Knob, Reset	1
39		85000050		O-ring Grease, DuPont™ Krytox® GPL-201	A/R

Wet Pilot Line Single Interlock Preaction System

4" (100mm), 6" (150mm) & 165mm Sizes

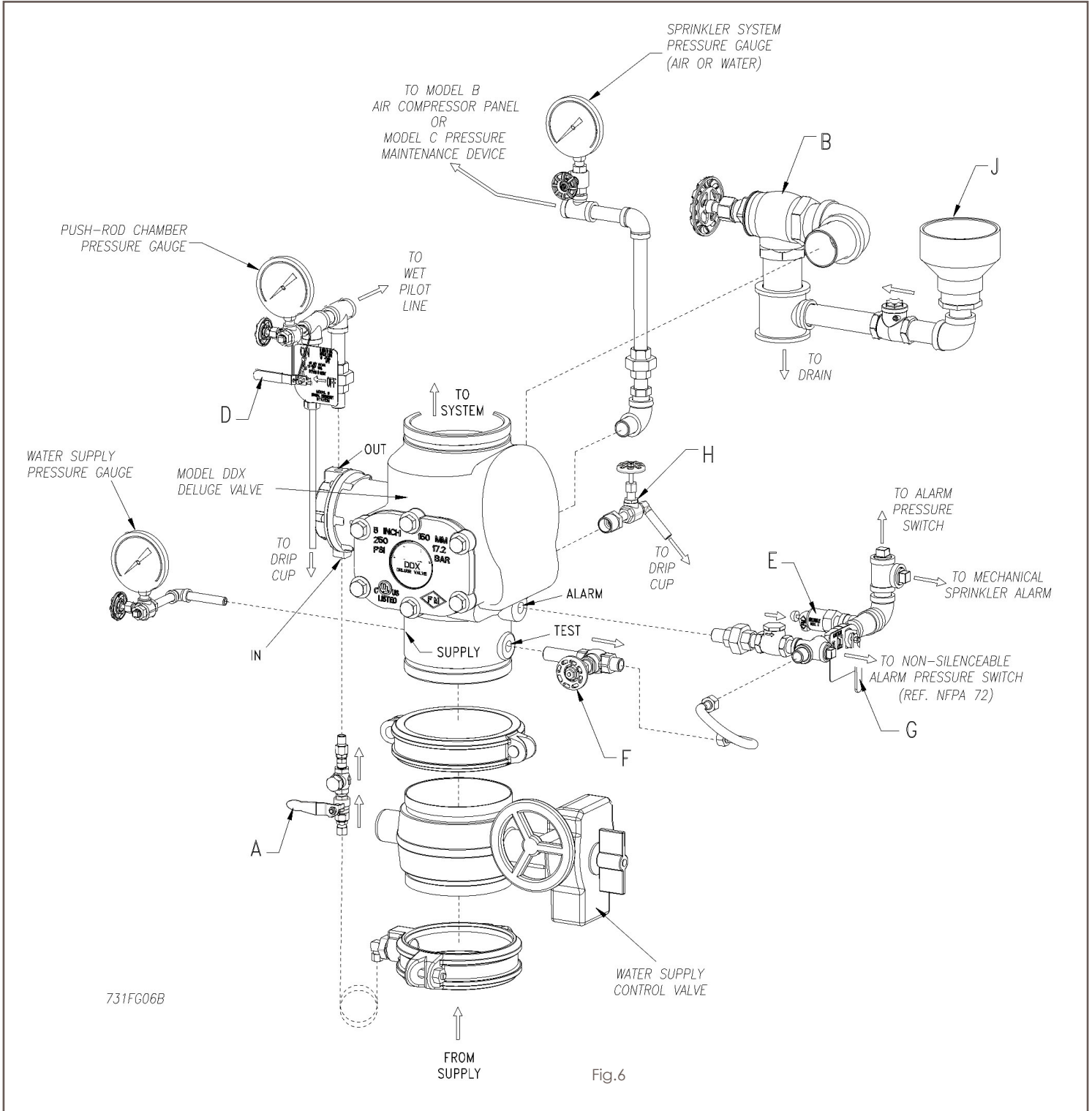



Wet Pilot Line Single Interlock Preaction System

4" (100mm), 6" (150mm) & 165mm Sizes

through 90 degrees about the centerline axis of the Model DDX Deluge Valve so that the lever side of the seat-clapper subassembly faces the outlet of the Deluge Valve. Rotate the seat-clapper subassembly around the centerline of the Deluge Valve until the top of the clapper faces the handhold opening and then pull it out clapper hinge-pin side first. Visually examine all components of the seat-clapper subassembly replacing any component that appears damaged. New O-rings (#11, Fig. 5) should always be used for reassembly.

Reassembly:

It is likely that the lower seat O-ring (#11, Fig. 5) has remained at the bottom of the Deluge Valve body's bore. Discard this O-ring and clean the bore. Lubricate the bore with O-ring grease and place the lower seat O-ring on the step at the bottom of the bore, verifying that it is in full contact with the bore. Lubricate the bottom step and upper seat O-ring (#11, Fig. 5) of the refurbished seat-clapper subassembly. Insert the seat-clapper subassembly into the handhold opening of the Deluge Valve lever-first, rotating it until the lever side faces the outlet of the Deluge Valve. Rotate the seat-clapper subassembly until the lever (#7, Fig. 5) faces the push rod (#20, Fig. 5), then drop the seat-clapper subassembly into the Deluge Valve's bore. Verify that the seatclapper subassembly is in the fully down position and check to see that the lever lines up with the push rod. Adjust if necessary. Clean and lubricate the two locking pins (#17 (not shown) Fig. 5) with O-ring lubricant and drive them into the Deluge Valve body. Then reinstall the 3/8" NPT pipe plugs (#19 (not shown) Fig. 5). Reassemble the handhold cover and set up the Model DDX Deluge Valve as per the section "Resetting the Single Interlock Preaction System."

3. Leakage out of the push rod chamber vent hole:

A small bleed hole is located on the underside of the push rod chamber (see Fig. 5). If there is air or water leakage coming out of this hole, do the following:

- a .Shut down the valve controlling water supply to the Deluge Valve. Relieve the inlet pressure by opening the main drain valve B (Fig. 6). Close the valve A (Fig. 6) that supplies water to the push rod chamber, and open the Model B Manual Emergency Station, valve D (Fig.6).
- b .Remove the trim at the unions nearest to the push rod chamber cover (#8, Fig. 5).
- c .Take the push rod chamber cover (#8, Fig. 5) off by removing the six retaining screws (#29, Fig. 5).

CONDITION ONE (Water coming out of the bleed hole):

Water coming out of the bleed hole is caused by a leaking diaphragm (#34, Fig. 5). Visually inspect the push rod chamber cover (#8, Fig. 5) and piston (#18, Fig. 5) to determine what could have damaged the diaphragm and correct. Install a new diaphragm.

NOTE: The diaphragm has two different surfaces, it is not bi-directional. It will fail if installed backwards! Roll the diaphragm so that the smooth surface (the pressure side) conforms to the inside of the push rod chamber cover and reassemble the six retaining screws (#29, Fig. 5) with an installation torque of 15 footpounds. Set up the Model DDX Deluge Valve as per the section "Resetting the Single Interlock Preaction System."

CONDITION TWO (System Air coming out of the bleed hole):

System air coming out of the bleed hole is caused by a defective O-ring assembled to the push rod (#21, Fig. 5). Remove the piston-push rod subassembly, push rod spring (#32, Fig. 5), and push rod guide (#21, Fig. 5). Verify by hand turning, that the push rod cannot be unscrewed from the piston. Replace all O-rings and the push rod guide. The correct installation torque for the push rod guide is 35 inchpounds.

CAUTION: Do not over-tighten the push rod guide. Reassemble the components that were initially removed. Reinstall the diaphragm (#34, Fig. 5) if it appears to be in good shape, otherwise, replace it also. NOTE: The diaphragm has two different surfaces, it is not bi-directional. It will fail if installed backwards! Roll the diaphragm so that the smooth surface (the pressure side) conforms to the inside of the push rod chamber cover and reassemble the six retaining screws (#29, Fig. 5) with an installation torque of 15 footpounds. Set up the Model DDX Deluge Valve as per the section "Resetting the Single Interlock Preaction System."



Wet Pilot Line Single Interlock Preaction System

4" (100mm), 6" (150mm) & 165mm Sizes

Ordering Information

Specify

- Valve Model & Size - 4"(100mm) Model DDX Deluge Valve (P/N 6103040026), 6"(150mm) Model DDX Deluge Valve (P/N 6103060024), 165mm Model DDX Deluge Valve (P/N 6103060028).
- Trim - The trim set is available in individual parts, in time-saving segmentally assembled kit forms, or fully assembled to the Model DDX Deluge Valve with or without a control valve.

Trim Configurations	Trim Part Numbers		
	4" (100mm) Valve	6" (150mm) Valve	165mm Valve
Fully Assembled to DDX Valve w/Control Valve	6505040276	6505060276	Not Available
Fully Assembled to DDX Valve w/o Control Valve	6505040275	6505060275	6505065274
Segmentally Assembled (DDX Valve Sold Separately)	6503001711		
Individual Parts (DDX Valve Sold Separately)	6503001710		

Note: For metric installations, a 2" NPT x R2, ISO 7/1 x Close Nipple (Rapidrop P/N 98543401) is sold Separately as an adapter for the single drain outlet of the trims.

- Additional Equipment (Refer to Fig. 7)

Item No.	Component Part	Mfr.	Description	Technical Bulletin
1.	Water Supply Control Valve	Select	OS&Y, 4"(100mm), 6" (150mm) or 165mm	-
			Butterfly, 4"(100mm), 6" (150mm) or 165mm	-
	Tamper Switch (Optional) for OS&Y Valve (Optional) for Butterfly Valve	B	Model OS&Y2	System Sensor A05-0196
			Model P1BV2	System Sensor A05-0197
2	Deluge Valve	A	Model DDX, 4"(100mm), 6" (150mm) or 165mm	510 / 511
3	Single Interlock Trim Kit	A	Refer to Parts List in this Bulletin	731
4	Waterflow Alarm Pressure Switch	B	Model EPS10-2 (DPDT, UL, FM)	-
			Model EPSA10-2 (DPDT, ULC)	System Sensor A05-0176
5	Mechanical Alarm (Optional)	A	Model C	612 / 613
6	Manual Emergency Station	A	Model A	Hydraulic (Pilot Line) Type 506
7	Pilot Line Detector / Sprinkler	A	Model F1-FTR	180
8	Sprinklers	A	Closed Type	110, 117, 131, 136, etc.
9	Supervisory Air Pressure Supply	A	Model B Air Compressor Panel	252
			Model C Pressure Maintenance Device	

System Equipment Manufacturers

- (A) Rapidrop
(B) System Sensor

Wet Pilot Line Single Interlock Preaction System

4" (100mm), 6" (150mm) & 165mm Sizes

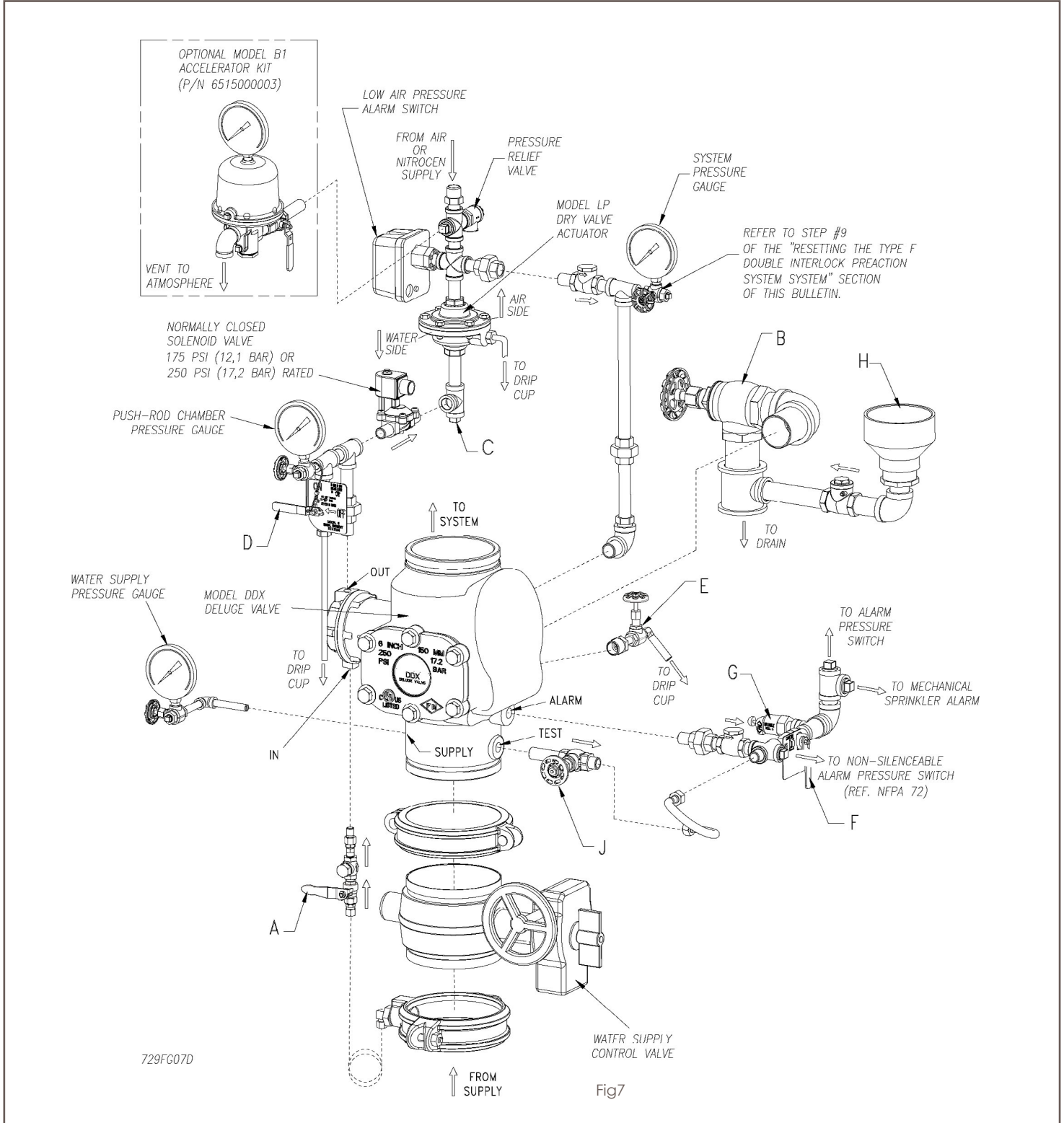

Wet Pilot Line Single Interlock Preaction System

4" (100mm), 6" (150mm) & 165mm Sizes

Installation Dimensions in Inches (mm)

Installation Dimensions in Inches (mm)

Valve	A	B	C	*D	E	F	G	H	J	K	L	M	N	P	Q	R
4" (100mm)	5¼ (133)	6¾ (171)	9½ (241)	14 (355)	25¼ (641)	27½ (699)	8½ (216)	6 (152)	5½ (140)	8½ (216)	13½ (343)	2½ (64)	6¼ (159)	7 (178)	12 (305)	14 5/8 (371)
6" (150mm) & 165mm	6¼ (159)	7¾ (197)	10½ (267)	16 (406)	26¼ (667)	29½ (749)	8½ (216)	6 (152)	5½ (140)	8½ (216)	13½ (343)	3¼ (83)	8¾ (222)	6½ (165)	12½ (218)	14 5/8 (371)

* Total take out dimension for Fully Assembled to DDX Valve w/Control Valve Configurations:

4" - 207/16, 6" - 233/4", 165 mm - N/A.

TRIM SHOWN FULLY ASSEMBLED WITHOUT CONTROL VALVE

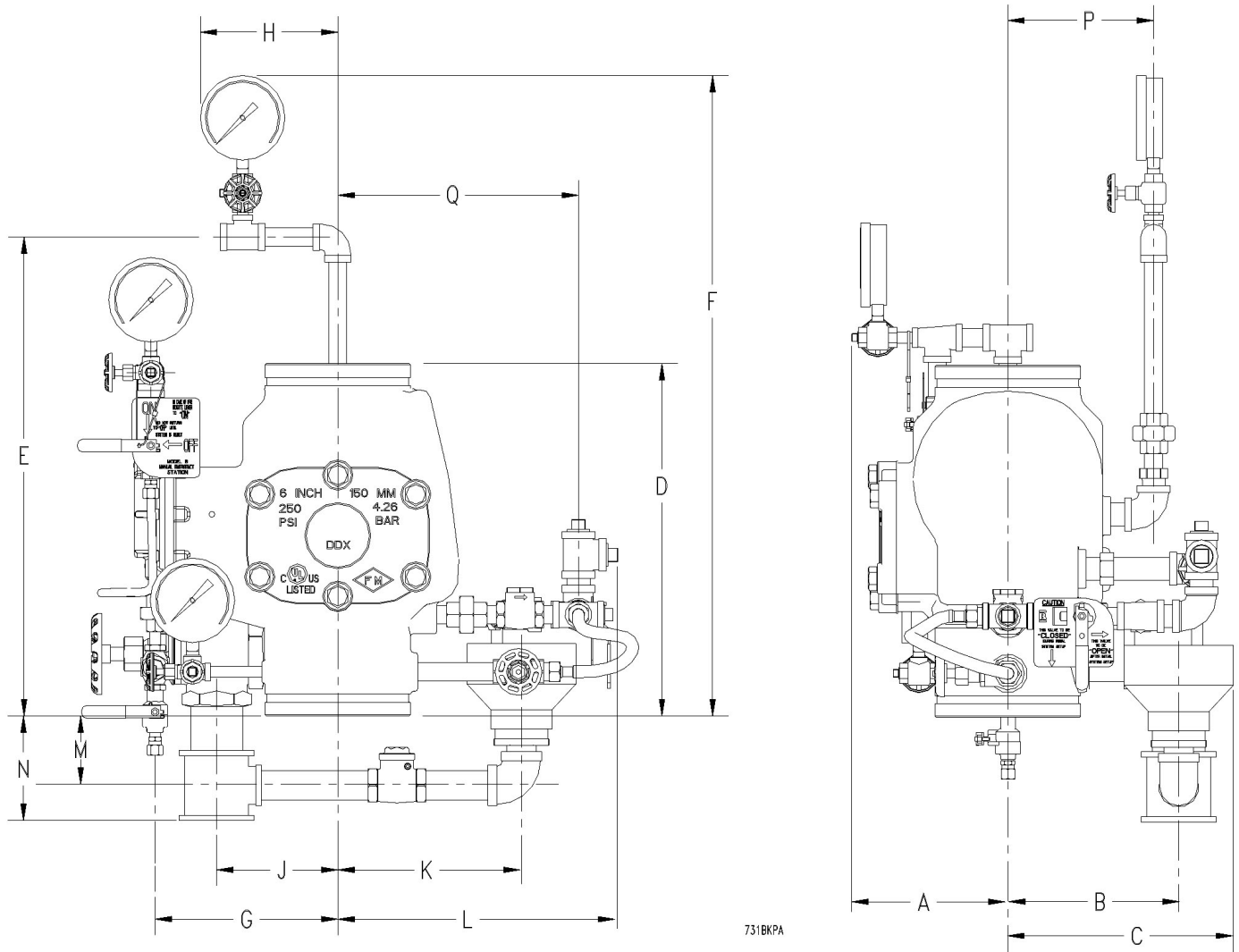



Wet Pilot Line Single Interlock Preaction System

4" (100mm), 6" (150mm) & 165mm Sizes

Rapidrop...For Complete Protection

Rapidrop offers a wide selection of sprinkler components. Following are some of the many precision-made Reliable products that guard life and property from fire around the clock.

- Automatic sprinklers
- Flush automatic sprinklers
- Recessed automatic sprinklers
- Concealed automatic sprinklers
- Adjustable automatic sprinklers
- Dry automatic sprinklers
- Intermediate level sprinklers
- Open sprinklers
- Spray nozzles
- Alarm valves
- Retarding chambers
- Dry pipe valves
- Accelerators for dry pipe valves
- Mechanical sprinkler alarms
- Electrical sprinkler alarm switches
- Water flow detectors
- Deluge valves
- Detector check valves
- Check valves
- Electrical system
- Sprinkler emergency cabinets
- Sprinkler wrenches
- Sprinkler escutcheons and guards
- Inspectors test connections
- Sight drains
- Ball drips and drum drips
- Control valve seals
- Air maintenance devices
- Air compressors
- Pressure gauges/identification signs
- Fire department connection