



Post Indicator Supervisory Switch

Model: PCVS-2

Product Description

The Model PCVS-2 is a weather proof and tamper resistant switch for monitoring the open position of fire sprinkler control valves of the wall and yard post indicator and butterfly types. Two SPDT (Form C) contacts are provided which will operate when the valve position is altered from an open state.

The unit mounts in a 1/2" NPT tapped hole in the post indicator or butterfly valve housing. The device is engaged by the indicating assembly of the post indicator or the operating mechanism of the butterfly valve, actuating switches when the valve is fully open. The unit should be installed where it is accessible for service. The cover is held in place by two tamper resistant screws that require a special tool to remove. The tool is furnished with each device.

Features

- NEMA 4X* and 6P (IP 67)
- *Enclosure is 4X. For additional corrosion protection of mounting hardware, use model PCVS-2 CRH
- -40°C to 60°C (-40°F to 140°F) operating temperature range
- Visual Switch Indicators
- Two conduit entrances
- Adjustable length trip rod
- Accommodates up to 12AWG wire
- Switch detects tampering and valve closure
- RoHS compliant
- Two SPDT contacts

Testing

The operation of the PCVS-2 and its associated protective monitoring system shall be tested upon completion of the installation and inspected, tested and maintained in accordance with all applicable local and national codes and standards and/or the Authority Having Jurisdiction, (manufacturer recommends quarterly or more frequently). A minimum test shall consist of turning the valve operating mechanism towards the closed position. The PCVS-2 shall operate within the first two revolutions of the operating mechanism. Fully close the valve and ensure the PCVS-2 does not restore. Fully open the valve and ensure that the PCVS-2 restores to normal.

Notice

Before any work is done on the fire sprinkler or fire alarm system, the building owner or their authorized representative shall be notified.
Before opening any closed valve, ensure that opening the valve will not cause any damage from water flow due to open or missing sprinklers, piping, etc.



Technical Details

Enclosure	Cover: Die Cast Finish: Red Powder Coat Base: Die Cast Finish: Black Powder Coat All parts have corrosion resistant finishes
Cover Tamper	Tamper Resistant Screws Optional Cover Tamper Switch Available
Contact Ratings	PCVS-2: Two Sets of SPDT (Form C) 10.0 Amps at 125/250 VAC 2.0 Amps at 30VDC Resistive 10 mAmps minimum at 24 VDC
Environmental Limitations	-40°C to 60°C (-40° F to 140° F) NEMA 4X and NEMA 6P (IP 67) Enclosure (Use suitably rated conduit and connector) Indoor or Outdoor Use
Conduit Entrances	Two Knockouts for 1/2" conduit provided (See Fig.6 on Page 4 and Notice on Page 5)
Service Use	Automatic Sprinkler - NFPA-13 One or two family dwelling - NFPA-13D Residential occupancy up to four stories - NFPA-13R National Fire Alarm Code - NFPA-72
Weight	0.45 kg (1 lbs)

Manufactured by Potter who hold FM Approval, UL Listing and CE Certificate

DS: 2.31
Issue A
05/05/2021
© 2021 Rapidrop

Rapidrop Global Ltd
T: +44 (0) 1733 847 510 F: +44 (0) 1733 553 958
e: rapidrop@rapidrop.com
w: www.rapidrop.com

Post Indicator Supervisory Switch Model: PCVS-2

Theory of Operation

The PCVS-2 is a spring loaded switch. It is in normal position when the trip rod is pulling against the spring force. Normal is when the switch is installed on the valve and the valve is fully open. As the valve closes, the valve actuator moves away from the trip rod of the PCVS-2 and the spring on the PCVS-2 pulls the trip rod over and trips the switch.

Alternate Window Installation and Moving Hood Installation

Target moves up as valve is shut:

Subject to the approval of the "authority having jurisdiction" the alternate method of installation shown in Fig. 1 may be used. In this method, one of the glass windows of the housing is replaced with a 1/4" thick metal plate that is cut to fit in place of the glass and drilled and tapped to receive 1/2" NPT pipe nipple. In some cases it may be necessary to attach an angle bracket to the target assembly to engage the PCVS-2 trip rod.

Fig 1

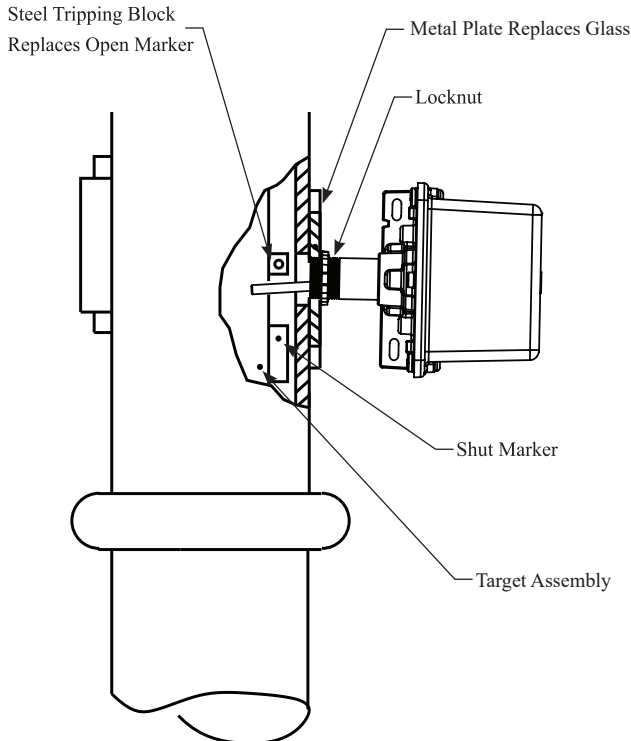

Hood moves down as valve is shut:

If the target is stationary and a hood arrangement is used, such as is shown in Fig. 2, the hood must be drilled with a 23/32" drill and tapped with a 1/2" NPT. The center line of this hole should be 1/8" below the portion of target assembly that strikes the PCVS-2 trip rod. The 11 3/8" dimension shown is for a Clow Valve. Flexible conduit must be used for this type of installation. (More on pg. 3).

Fig 2

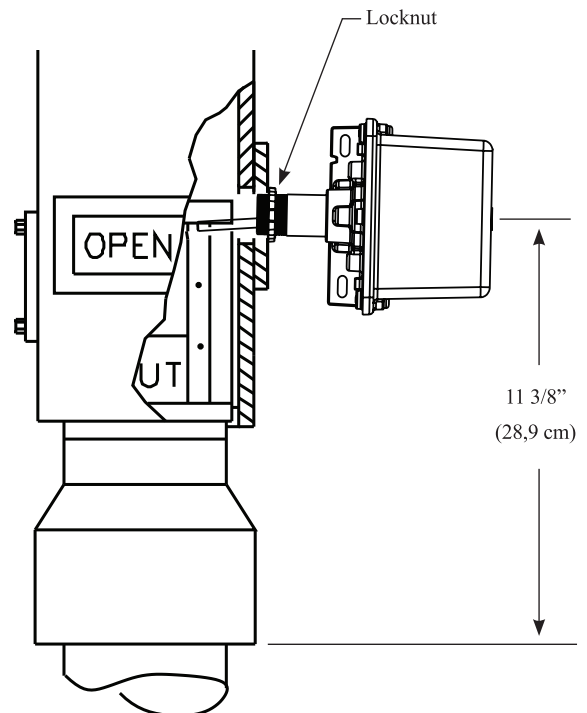

Post Indicator Supervisory Switch

Model: PCVS-2

Typical Installations on Post Indicator Valve Housing

Note: Before any work is done on the fire sprinkler or fire alarm system, the building owner or their authorized representative should be notified. Before opening any closed valve, ensure that opening the valve will not cause any damage from water flow due to open or missing sprinklers, piping, etc.

1. Position the valve to fully open ("OPEN" should appear in the window of the housing). Partially close the valve while observing the direction that the target assembly moves. Reopen the valve. If the valve housing is predrilled with 1/2" NPT for installation of a monitoring switch, remove the 1/2" plug and fully open the valve. Make sure that "OPEN" appears in the window of the housing. GO TO STEP NO. 6.
2. If the valve is not pre-drilled for 1/2" NPT, remove the head and target assembly (consultation with valve manufacturer is recommended).
3. If the target assembly moved up as the valve was closed, measure the distance from the bottom of the head to the lower part of the target assembly that will contact the trip rod of the PCVS-2 (see Fig. 3). This is usually a plate or bar on the target assembly, on a side adjacent to the "OPEN/SHUT" plates. Subtract 1/8" from the measurement. If the target moved down as the valve was closed, measure the distance from the bottom of the head to the upper portion of the target assembly that will contact the trip rod of the PCVS-2 (see Fig. 4). Add 1/8" (3,2mm) to this measurement.
4. Mark the housing at the proper location. Using a 23/32" (18,2mm) drill bit, drill and then tap a 1/2" NPT in the housing on the side that coincides with the portion of the target assembly that will engage the trip rod of the PCVS-2.
5. Replace the head and target assembly.
6. Loosen the socket head screw that holds the nipple in the PCVS-2 and remove the nipple.
7. Screw the locknut that is provided onto the nipple.
8. Screw the nipple into the 1/2" NPT hole in the valve housing hand tighten. Tighten the locknut against the valve housing to secure the nipple firmly in place.
9. Insert a scale or probe thru the nipple to measure the distance from the open end of the nipple to the target assembly. Subtract 1/2" (12,5mm) from this measurement.

Note: In some cases, it may be necessary to attach an angle bracket to the target assembly to engage the PCVS-2 trip rod.

10. Using the special tool provided, loosen the two cover screws and remove the cover from the PCVS-2.
11. Loosen the locking screw that holds the trip rod in place and adjust the rod length, from the end of the collar to the end of the rod, using the dimension determined in Step 9. Tighten the locking screw to 5 in-lbs minimum to hold the rod in place and properly seal the enclosure.
12. Partially close the valve to move the target assembly away (3 to 4 revolutions of the handle/hand wheel).
13. With the PCVS-2 positioned so the spring will pull the trip rod to follow the target as the valve is closing, slide the PCVS-2 over the nipple. Tighten the socket head screw in the collar.
14. Carefully open the valve to the fully open position. As the target moves to the open position it should engage the trip rod and actuate the switch(es). There should be a minimum overtravel of 1/2 revolution of the handle/hand wheel after the switch(es) actuate (a continuity meter connected to each set of contacts is one method that could be used to determine this).
15. Slowly close the valve. The switch must operate during the first two revolutions of the handle/hand wheel or during 1/5 of the travel distance of the valve control apparatus from its normal condition. **Note:** Small adjustments of the target position may be necessary (consultation with valve manufacturer is recommended).
16. Complete the required electrical wiring, connections and tests. The valve should be operated through the entire cycle of fully closed and fully open to determine the integrity of the PCVS-2 installation and the signaling system. Check that all electrical and mechanical connections are secure.
17. Reinstall the cover and tighten the cover screws to 15 in-lbs minimum to properly seal the enclosure.
18. When the installation and testing are complete, return valve to its proper position.
19. Alternative installation for other post indicator valve housing shown in Fig. 1 and 2.

Fig 3

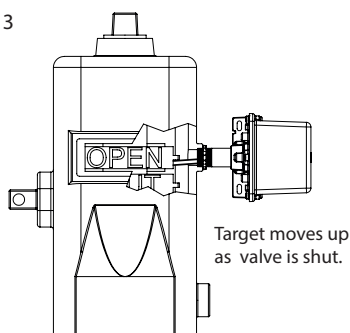
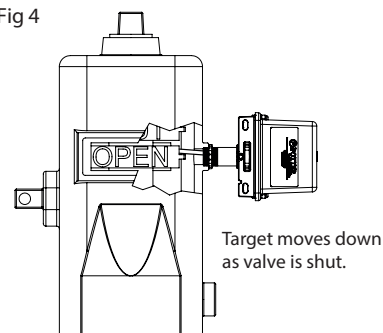

Fig 4



Manufactured by Potter who hold FM Approval, UL Listing and CE Certificate

Post Indicator Supervisory Switch

Model: PCVS-2

Dimensions

Fig 5

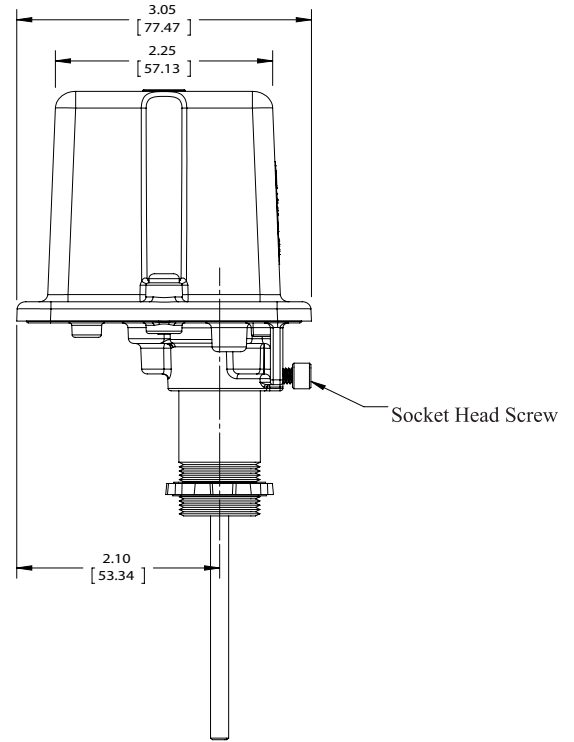
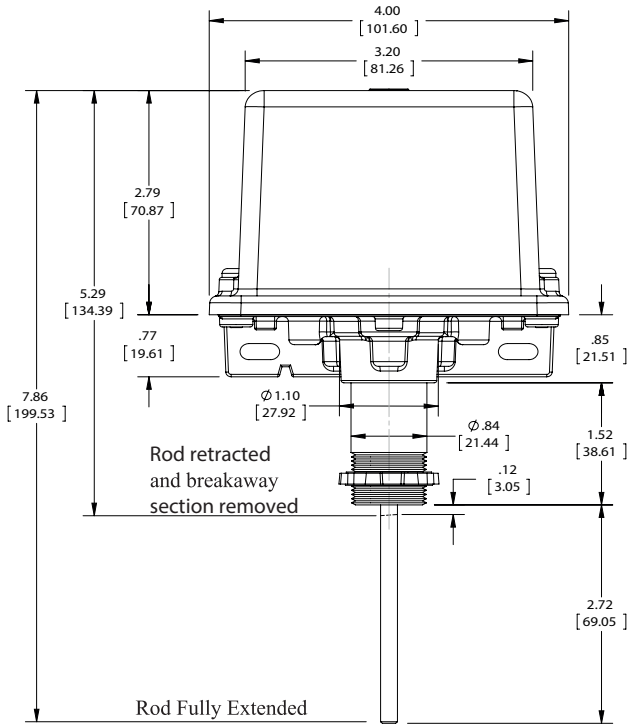

Knockout Removal

Fig 6

To remove knockouts: Place screwdriver at inside edge of knockout, not in the center.

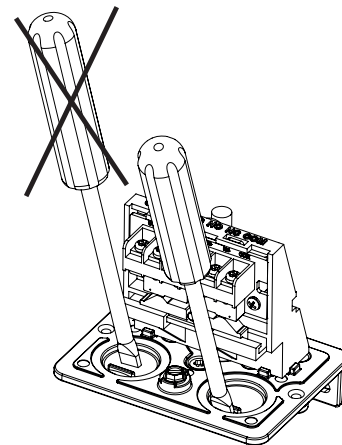
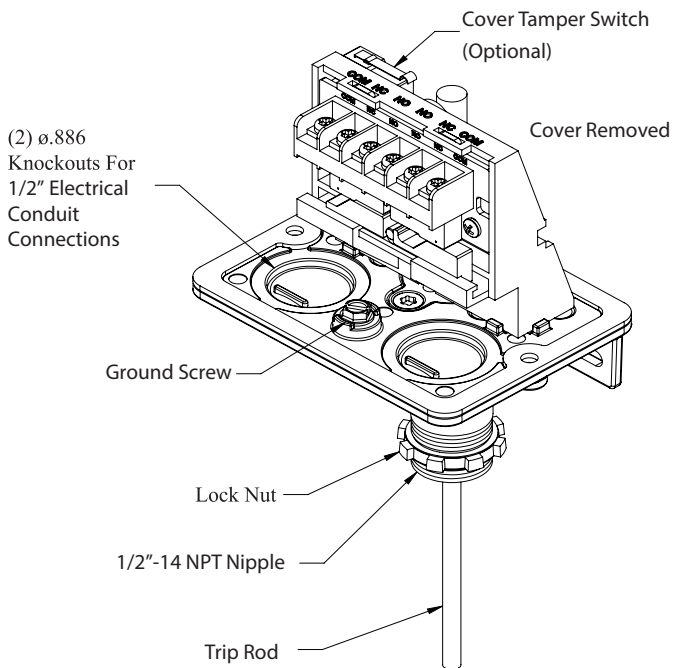

Manufactured by Potter who hold FM Approval, UL Listing and CE Certificate



Post Indicator Supervisory Switch Model: PCVS-2

Breaking Excessive Rod Length

Fig 7

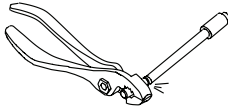

Typical Electrical Connections

Fig 9

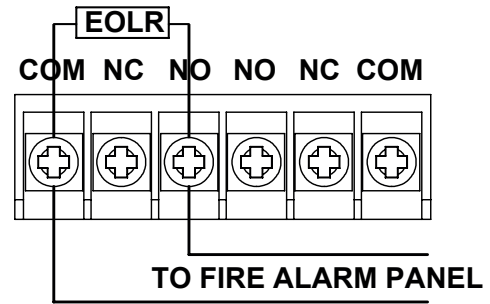

Switch Terminal Connections Clamping Plate Terminal

Fig 8

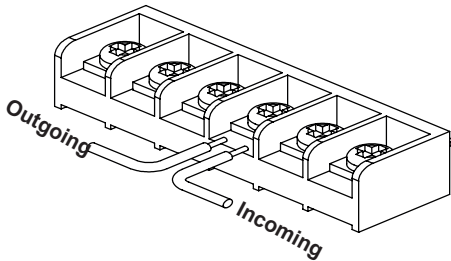

Warning

An uninsulated section of a single conductor should not be looped around the terminal and serve as two separate connections. The wire must be severed, thereby providing supervision of the connection in the event that the wire become dislodged from under the terminal. Failure to sever the wire may render the device inoperable risking severe property damage and loss of life. Do not strip wire beyond 3/8" of length or expose an uninsulated conductor beyond the edge of the terminal block. When using stranded wire, capture all strands under the clamping plate.

Notice

All conduit and connectors selected for the installation of this product shall be suitable for the environment for which it is to be used and shall be installed to the manufacturer's installation instructions. For NEMA 4, 4X, 6, 6P installations, the cover screws are recommended to be tightened to 15 inlbs minimum and the trip rod locking screw tightened to 5 in-lbs minimum to properly seal the enclosure.

Manufactured by Potter who hold FM Approval, UL Listing and CE Certificate

DS: 2.31
Issue A
05/05/2021
© 2021 Rapidrop

Rapidrop Global Ltd
T: +44 (0) 1733 847 510 F: +44 (0) 1733 553 958
e: rapidrop@rapidrop.com
w: www.rapidrop.com