



PIV NRS Flanged Gate Valve Fig. 104FF

Product Description

Rapidrop Fig.104FF Valve is a manually operated, non rising stem resilient wedge gate valve designed for use in fire protection systems for on/off operation only. The lightweight ductile iron body allows for easier handling and reduced shipping costs. Valves are suitable for both vertical and horizontal installation. Rapidrop vertical post indicator and Rapidrop wall post indicator, are available separately.

Valve components are corrosion resistant or coated with a thermally applied fusion-bonded epoxy. The EPDM encapsulated ductile iron wedge with a compression mechanism is designed to achieve water tight sealing and low torque operation.



Maximum Working Pressure

DN50 - DN250 (2" - 10") - 20.7 bar (300 psi)
DN300 (12") - 17.2 bar (250 psi)

Maximum Working Temperature

71°C / 160°F

Coating

Fusion Bonded Epoxy Coating in accordance with ANSI /AWWA C550

Flange Specification

ANSI 125/ANSI 150 flat face (raised face available on request)
PN16 raised face

Design Standard

Conforms to AWWA C509-09

Approvals

FM Approved
UL Listed
CNBOP Certificate

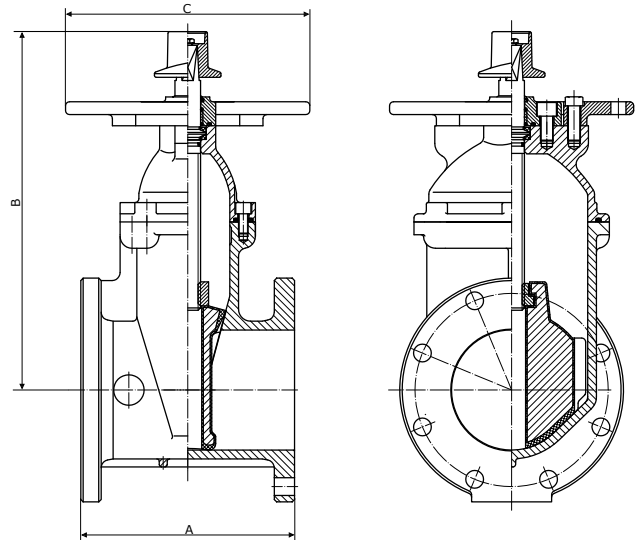

Sizes

Sizes		Dimensions (mm)			Number of Drain Plugs	Drain Plug Size	Turns to Open	Weight (Kg)	Product Ordering Code	
mm	Inch	A	B	C					ANSI	PN16
DN50*	2"*	178	270	305	1	1/2" NPT	6.3	9.6	RD104FF050A	RD104FF050
DN65	2½"	190	293	305	1	1/2" NPT	8.8	16	RD104FF065A	RD104FF065
DN80	3"	203	322	305	1	1/2" NPT	10.6	20	RD104FF080A	RD104FF080
DN100	4"	229	352	305	1	1/2" NPT	13	32	RD104FF100A	RD104FF100
DN150	6"	267	445	305	1	3/4" NPT	15.6	55	RD104FF150A	RD104FF150
DN200	8"	292	528	305	1	3/4" NPT	17.3	89	RD104FF200A	RD104FF200
DN250	10"	330	617	305	1	1" NPT	21.4	134	RD104FF250A	RD104FF250
DN300	12"	356	705	305	1	1" NPT	25.3	194	RD104FF300A	RD104FF300

*DN50 FM Approved only

Note: Ordering codes for European countries. For other areas please contact your local Rapidrop sales representative.



PIV NRS Flanged Gate Valve

Fig. 104FF

Installation

Rapidrop Fig.104FF Flanged Gate Valve is suitable for indoor and outdoor use. The valve should be installed in a location easily accessible for operation and maintenance. The valve may be installed in any position and the flow may be from either direction through the valve. Valves should be supported independently to prevent the movement and stresses from the connecting piping system.

1. Visually inspect the valve, make sure that the connecting flanges are clean of debris and any foreign materials.
2. Ensure that valve is in the closed position during handling and installation process.
3. Insert the valve with appropriate gaskets between the flanges and tighten all flange bolts using the crossover method.
4. After tightening the bolts check the operation by fully opening and closing the valve.
5. Before pressurising the system make sure the valve is in fully open position.

Care and Maintenance

The valve should never be forced to seat by applying a wrench to the stem as this may distort the valve components. The use of excessive force to open or close the valve violates all warranties.

The valve should not be used to force a pipeline into position as this may result in the damage of the valve components.

Rapidrop gate valves require no regular maintenance, however it is advisable to inspect and verify proper operation of the unit annually or in accordance with the authority having jurisdiction.

The inspection should include a visual check for leakage at the pipe connection. Inspection and maintenance should be performed by a competent person in accordance with national codes/ requirements.

Debris in the piping system might cause difficulties in closing the valve, this problem can be overcome by backing off the wrench/ handwheel and closing the valve again.

Rapidrop Figure 104FF Flanged Gate Valves are suitable for both indoor and outdoor use. Minor degradations of surface finish should not affect the performance of the valve.

Valve Closing Torque

Sizes	Closing Torque	Sizes	Closing Torque
DN50 2"	27 Nm	DN150 6"	149 Nm
DN65 2 1/2"	38 Nm	DN200 8"	203 Nm
DN80 3"	70 Nm	DN250 10"	251 Nm
DN100 4"	102 Nm	DN300 12"	305Nm

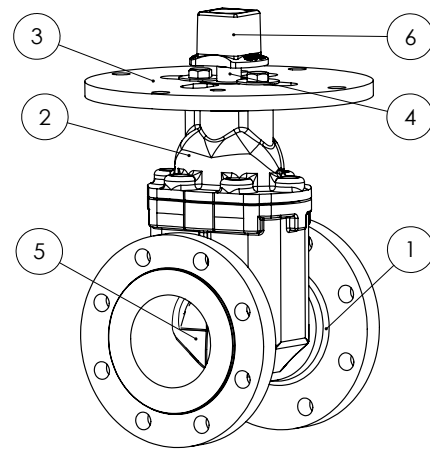

Material Specification

No	Description	Material
1	Valve Body	Ductile Iron ASTM A 536
2	Bonnet	Ductile Iron ASTM A 536
3	Indicator Mounting Flange	Ductile Iron ASTM A 536
4	Stem	Bronze ASTM B 150 UNS C61400 Optional Stainless Steel ASTM A276
5	Resilient Wedge	Ductile Iron ASTM A 536 EPDM ASTM D 2000
6	Drive Nut*	Gray Cast Iron ASTM A 126-B

*Note: 2" Taper square Drive Nut for all valve sizes.

Important Installation Information

- Rapidrop Figure 104FF Flanged Gate Valve must only be installed by a competent person in accordance with requirements of the local authority having jurisdiction. Deviations from these standards will invalidate warranty.
- It is the responsibility of the installing contractor to include a copy of this document in the sprinkler system installation, operating and maintenance manual.
- Alterations to Rapidrop products will void any warranty.
- Figure 104FF Flanged Gate Valve should be inspected and maintained during routine sprinkler system inspections by a competent person in accordance with national codes/requirements.
- Failure to follow these instructions could cause improper operation, resulting in personal injury and/or property damage.
- For further details and technical support please contact your Rapidrop sales representative.